

REV.	DATE	ECO	DESCRIPTION	BY	CK	APP
-	9/24/10	N/A	INITIAL RELEASE	RB		N/A

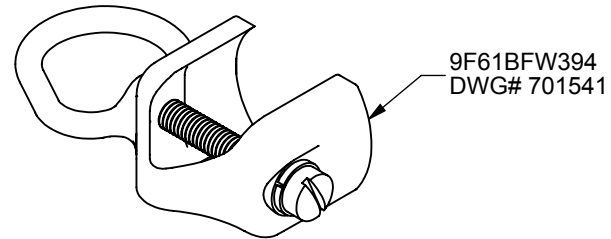

DIMENSIONS IN [] ARE MILLIMETERS

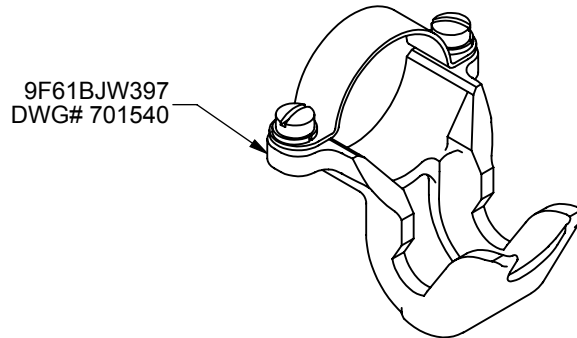
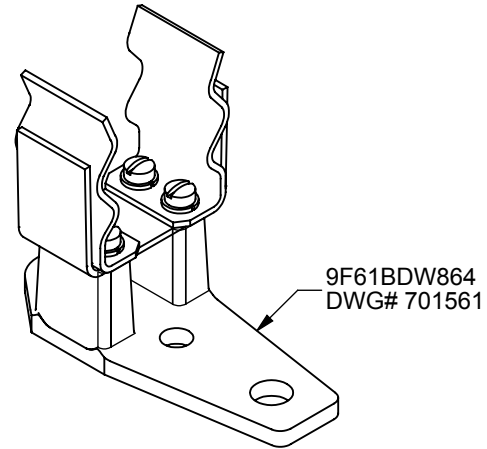
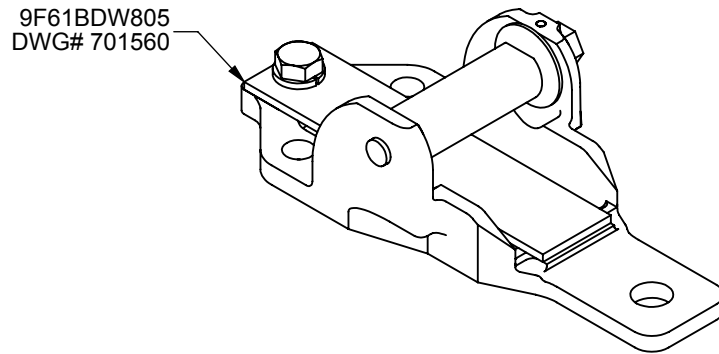

MERSEN USA NEWBURYPORT-MA, LLC
374 MERRIMAC STREET
NEWBURYPORT, MA 01950

9F61BNW731
SP 2 IN. D LIVE PARTS FD

OUTLINE DIMENSIONS
NOT TO BE USED FOR PRODUCTION

701542

PRODUCT MANAGER

DESIGN ENGINEER

SIGN:

SIGN:

DATE:

DATE:

REV.	DATE	ECO	DESCRIPTION	BY	CK	APP
-	9/27/10	N/A	INITIAL RELEASE	RB		N/A

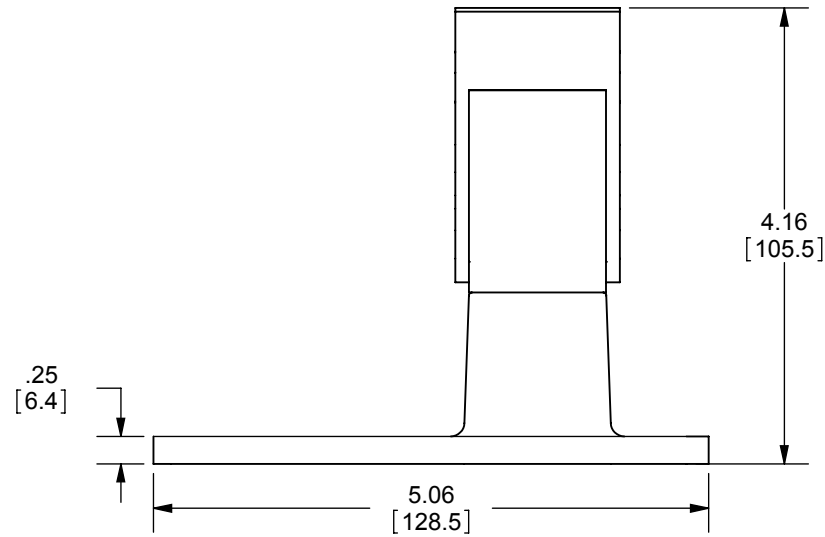
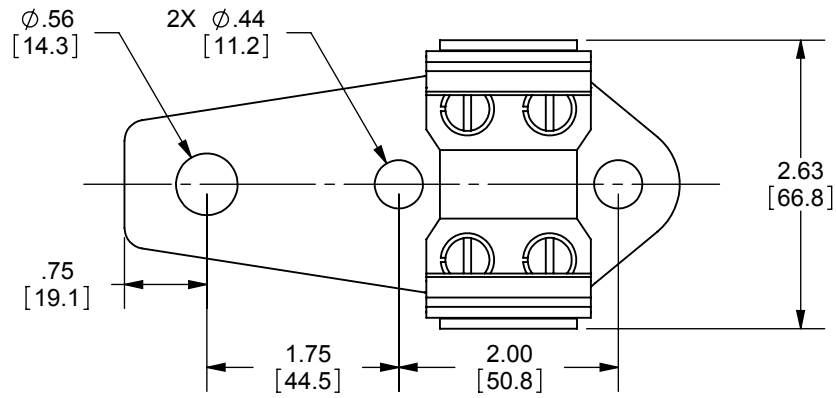

DIMENSIONS IN [] ARE MILLIMETERS



MERSEN USA NEWBURYPORT-MA, LLC
374 MERRIMAC STREET
NEWBURYPORT, MA 01950

9F61BDW864
2 IN. CLIP ASSY
SHORT TAB FD

OUTLINE DIMENSIONS
NOT TO BE USED FOR PRODUCTION

701562

PRODUCT MANAGER

DESIGN ENGINEER

SIGN:

SIGN:

DATE:

DATE:

REV.	DATE	ECO	DESCRIPTION	BY	CK	APP
-	9/20/10	N/A	INITIAL RELEASE	RB		N/A

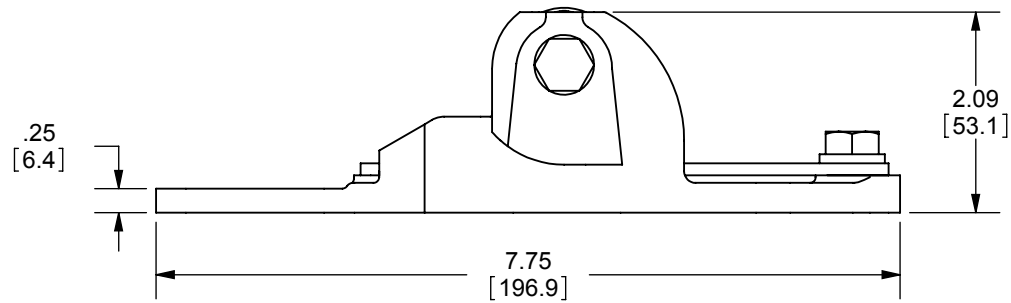
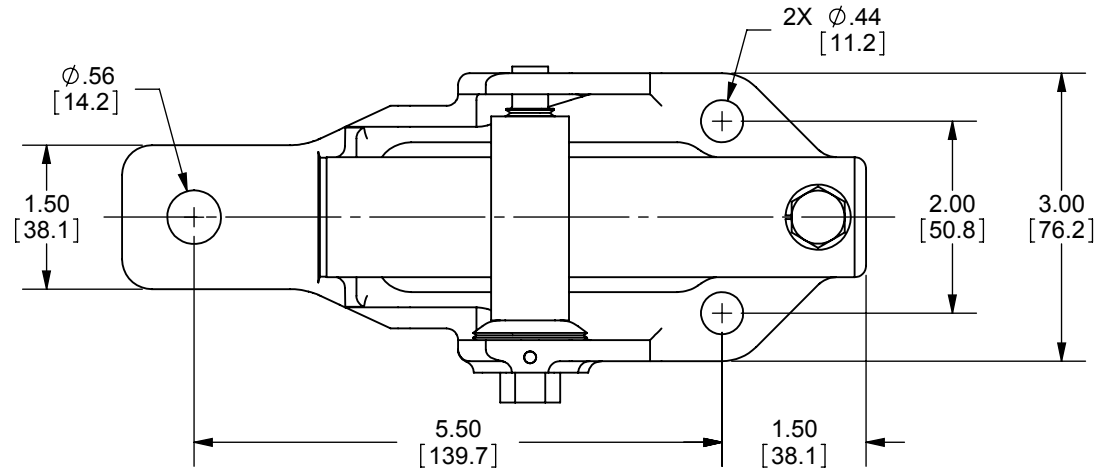

DIMENSIONS IN [] ARE MILLIMETERS



MERSEN USA NEWBURYPORT-MA, LLC
374 MERRIMAC STREET
NEWBURYPORT, MA 01950

9F61BDW805
HINGE SUPPORT
SHORT TAB FD

OUTLINE DIMENSIONS
NOT TO BE USED FOR PRODUCTION

701560

PRODUCT MANAGER

SIGN:

DATE:

DESIGN ENGINEER

SIGN:

DATE:

REV.	DATE	ECO	DESCRIPTION	BY	CK	APP
-	8/30/10	N/A	INITIAL RELEASE	RB	NA	N/A

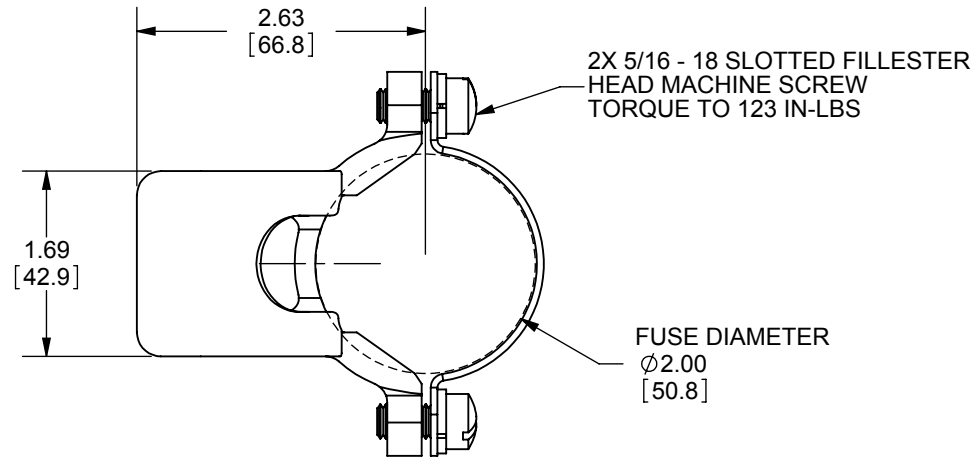
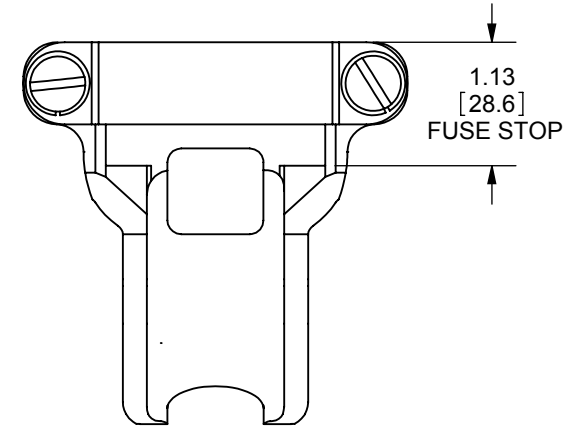
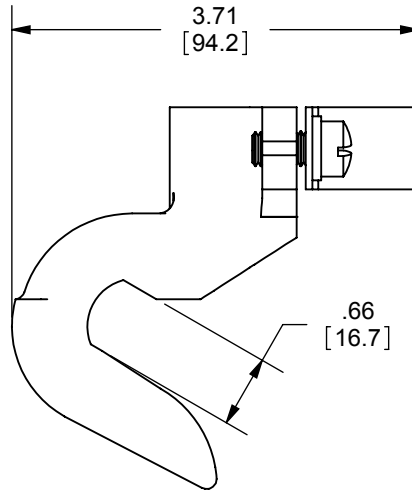
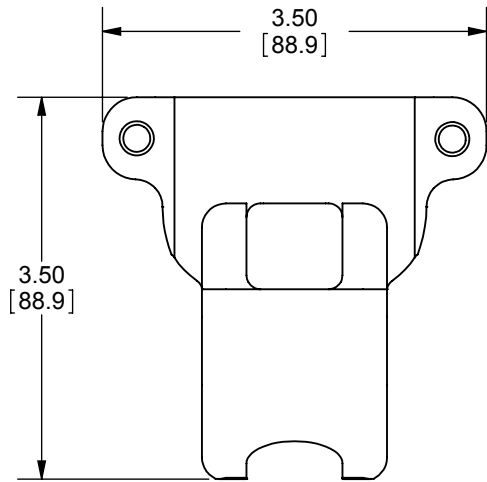

DIMENSIONS IN [] ARE MILLIMETERS



MERSEN USA NEWBURYPORT-MA, LLC
374 MERRIMAC STREET
NEWBURYPORT, MA 01950

PRODUCT MANAGER

DESIGN ENGINEER

SIGN:

SIGN:

DATE:

DATE:

9F61BJW397
2 IN. HINGE TRUNION FD

OUTLINE DIMENSIONS
NOT TO BE USED FOR PRODUCTION

701540

REV.	DATE	ECO	DESCRIPTION	BY	CK	APP
-	9/23/10	N/A	INITIAL RELEASE	RB	NA	N/A

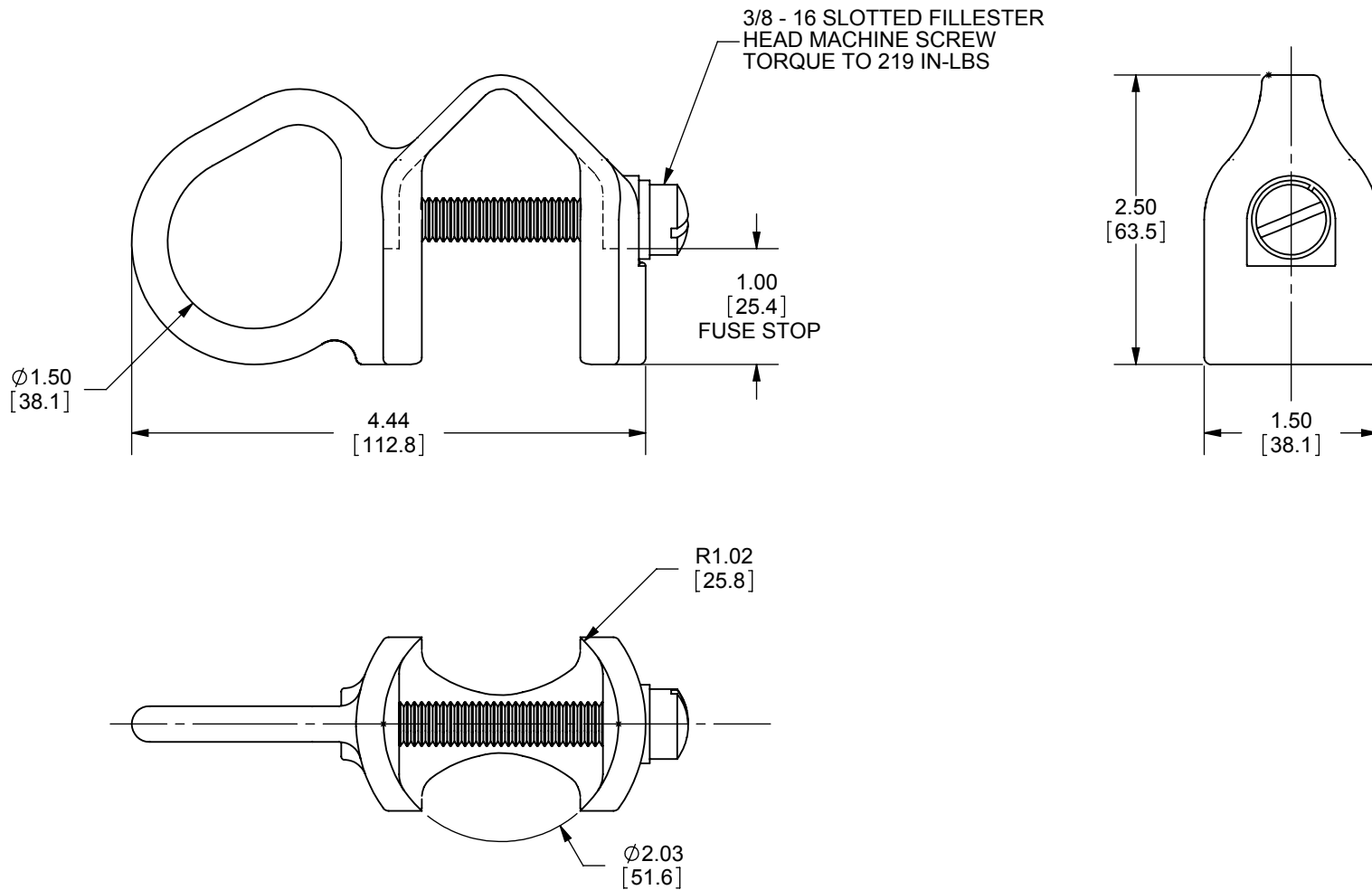

DIMENSIONS IN [] ARE MILLIMETERS



MERSEN USA NEWBURYPORT-MA, LLC
374 MERRIMAC STREET
NEWBURYPORT, MA 01950

9F61BFW394
2 IN. OPERATING EYE FD

OUTLINE DIMENSIONS
NOT TO BE USED FOR PRODUCTION

701541

PRODUCT MANAGER

SIGN:

DATE:

DESIGN ENGINEER

SIGN:

DATE: